

*Alabama Reading and Mathematics Test*

**Item Specifications**

**for**

**Mathematics**

**Grade 5**

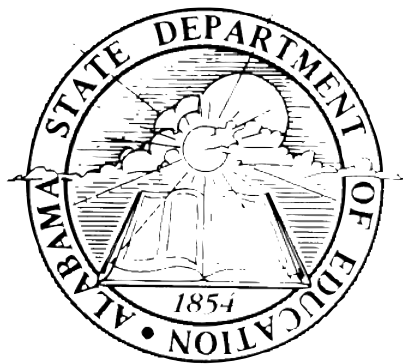

**Dr. Joseph B. Morton**  
**State Superintendent of Education**  
**Alabama State Department of Education**  
**Montgomery, Alabama**  
**Bulletin 2005, No. 86**

No person shall be denied employment, be excluded from participation in, be denied the benefits of, or be subjected to discrimination in any program or activity on the basis of disability, sex, race, religion, national origin, color, or age. Ref: Sec. 1983, Civil Rights Act, 42 U.S.C.; Title VI and VII, Civil Rights Act of 1964; Rehabilitation Act of 1973, Sec. 504; Age Discrimination in Employment Act; Equal Pay Act of 1963; Title IX of the Education Amendment of 1972: Title IX Coordinator, P.O. Box 302101, Montgomery, Alabama 36130-2101 or call (334) 242-8444.



Published by Harcourt Assessment, Inc.

Copyright © 2005 by the Alabama State Department of Education.

All rights reserved. No part of this publication may be reproduced or transmitted in any form or by any means, electronic or mechanical, including photocopy, recording, or any information storage and retrieval system, without permission in writing from the Alabama State Department of Education, except for the printing of complete pages, with the copyright notice, for instructional use and not for resale.

*HARCOURT* and the Harcourt Logo are trademarks of Harcourt, Inc., registered in the United States of America and/or other jurisdictions.

Produced in the United States of America.

**ARMT GRADE 5 MATHEMATICS**

**ALABAMA STATE BOARD OF EDUCATION**

Governor Bob Riley – President  
Randy McKinney – District 1  
Betty Peters – District 2  
Stephanie W. Bell – District 3  
Dr. Ethel H. Hall – District 4  
Ella B. Bell – District 5  
David F. Byers, Jr. – District 6  
Sandra Ray – District 7  
Dr. Mary Jane Caylor – District 8

**ALABAMA STATE DEPARTMENT OF EDUCATION**

Dr. Joseph B. Morton  
State Superintendent of Education

Dr. Ruth C. Ash  
Deputy State Superintendent of Education

Feagin Johnson, Jr.  
Assistant State Superintendent of Education

Dr. Gloria Turner  
Director, Student Assessment

**Student Assessment**

Miriam Byers, Education Administrator  
Cathy Poage, Education Administrator

Dorothy DeMars, Education Specialist  
Susan DuBose, Education Specialist  
Kanetra Germany, Education Specialist  
Shanetha Patterson, Education Specialist  
Nannette Pence, Education Specialist  
Susan Skipper, Education Specialist  
Mark Ward, Education Specialist

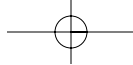

**ARMT GRADE 5 MATHEMATICS**

**TABLE OF CONTENTS**

**INTRODUCTION .....1**

**CONTENT STANDARDS .....2**

**ITEMS BY CONTENT STANDARD**  
**(with Answer Key at end of each Content Standard) .....3**

**SAMPLE RESPONSE FORMAT .....86**

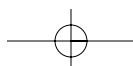
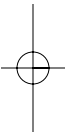
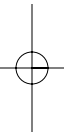

## ARMT GRADE 5 MATHEMATICS

### INTRODUCTION

This bulletin provides specific information about the *Alabama Reading and Mathematics Test (ARMT)*. Educators representing each State Board of Education district as well as both city and county school systems served on committees to determine the content standards on which the ARMT is based. In addition, educators from throughout the state of Alabama served on committees to review the content of the tests, including selecting and reviewing specific mathematics test items, and determining achievement levels.

Teachers must be familiar with the information in this bulletin so that they may incorporate effective teaching of the mathematics content standards with classroom assessments. Using classroom assessments with similar test formats from time to time will help to enable students to demonstrate proficiency on the various content standards in mathematics.

Three item types are included in the ARMT. Multiple-choice, gridded, and open-ended items assess student performance on the ARMT in mathematics. Multiple-choice items and gridded items carry a point value of one, while open-ended items carry a point value of three. In this document, teachers will see representative item types for each mathematics content standard.

<b>Content Standard</b>	A statement of what students should know and be able to do by the end of the academic year
<b>Item Type</b>	Multiple-choice, gridded, open-ended items
<b>Additional Information</b>	Further information about the test items for the content standard
<b>Sample Items</b>	A collection of item types for each content standard
<b>Answer Key</b>	Answers for multiple-choice items and gridded items
<b>Scoring Rubrics for Open-Ended Items</b>	Scoring guide for open-ended items

## ARMT GRADE 5 MATHEMATICS

### CONTENT STANDARDS Grade 5

CONTENT STANDARD	POINTS POSSIBLE
<p><b>Number and Operations</b></p> <p>1- Demonstrate number sense by comparing, ordering, rounding, and expanding whole numbers through millions and decimals to thousandths.</p> <p>2- Solve problems involving basic operations on whole numbers, including addition and subtraction of seven-digit numbers, multiplication with two-digit multipliers, and division with two-digit divisors.</p> <p>3- Solve word problems that involve decimals, fractions, or money.</p> <p>4- Determine the sum and difference of fractions with common and uncommon denominators.</p> <p>5- Identify numbers less than zero by extending the number line.</p>	<p>4</p> <p>6</p> <p>9</p> <p>6</p> <p><math>\frac{3}{28}</math></p>
<p><b>Algebra</b></p> <p>6- Demonstrate the commutative, associative, and identity properties of addition and multiplication of whole numbers.</p> <p>7- Write a number sentence for a problem expressed in words.</p>	<p>4</p> <p><math>\frac{4}{8}</math></p>
<p><b>Geometry</b></p> <p>8- Identify regular polygons and congruent polygons.</p> <p>9- Identify components of the Cartesian plane, including the x-axis, y-axis, origin, and quadrants.</p> <p>10- Identify the center, radius, and diameter of a circle.</p>	<p>3</p> <p>2</p> <p><math>\frac{2}{7}</math></p>
<p><b>Measurement</b></p> <p>11- Estimate perimeter and area of irregular shapes using unit squares and grid paper.</p> <p>12- Calculate the perimeter of rectangles from measured dimensions.</p> <p>13- Convert a larger unit of measurement to a smaller unit of measurement within the same system, customary or metric.</p>	<p>3</p> <p>3</p> <p>4</p> <p><b>10</b></p>
<p><b>Data Analysis and Probability</b></p> <p>14- Analyze data collected from a survey or experiment to distinguish between what the data show and what might account for the results.</p> <p>15- Use common fractions to represent the probability of events that are neither certain nor impossible.</p>	<p>6</p> <p>4</p> <p><b>10</b></p>
<b>TOTAL POINTS POSSIBLE</b>	<b>63</b>

**ARMT GRADE 5 MATHEMATICS****ITEMS BY  
CONTENT STANDARD****DIRECTIONS (These are the directions given to students.)**

Read the problem and find the answer.

If the problem has a multiple-choice answer, darken the bubble in the correct space in your answer document.

If the problem has an answer grid:

- Write your answer in the boxes at the top of the grid.
- Darken the correct bubble of the number or symbol in the column below.
- If your answer is a repeating decimal, round to the nearer hundredth.

For the problems that ask you to show your work, use the space given in your answer document.

- Be sure to show all your work or explain how you got your answer in the space given.
- If you use your calculator to get your answer, explain the steps you take.

For all problems, be sure to check your answers.

## ARMT GRADE 5 MATHEMATICS

## NUMBER AND OPERATIONS

**Content Standard 1**

Demonstrate number sense by comparing, ordering, rounding, and expanding whole numbers through millions and decimals to thousandths.

**Item Type**

Multiple-choice

**Additional Information**

Word problems/real-life situations may be used.

Tables and charts may be used only for graphic organization of information.

In comparing numbers, *greater than*, *greatest*, *less than*, or *least* may be used (symbols or words).

In ordering numbers, *greatest to least* or *least to greatest* may be used.

In rounding numbers, *closest* may be used.

**Sample Multiple-Choice Items**

1. Which of the following shows 9,678,345 in expanded form?

- A** 96,000,000 + 700,000 + 80,000 + 300 + 40 + 5
- B** 9,000,000 + 700,000 + 8,000 + 300 + 40 + 5
- C** 9,000,000 + 600,000 + 70,000 + 8,000 + 300 + 40 + 5 \*
- D** 9,000,000 + 600,000 + 70,000 + 8,000 + 300 + 40

2. Which of the following shows 7,500,902 in expanded form?

- A** 7,000,000 + 500,000 + 900 + 2 \*
- B** 7,000,000 + 50,000 + 900 + 2
- C** 700,000 + 50,000 + 9000 + 2
- D** 700,000 + 50,000 + 900 + 2

## ARMT GRADE 5 MATHEMATICS

3. Which statement below is true?

- A**  $878,999 > 888,373$
- B**  $200,883 < 200,873$
- C**  $551,321 < 516,323$
- D**  $775,843 > 775,795$  \*

6. Which statement below is true?

- A**  $0.065 < 0.160$  \*
- B**  $0.099 > 0.102$
- C**  $0.125 > 0.199$
- D**  $0.131 < 0.125$

4. Which number below has the *greatest* value?

- 0.108      0.118      0.109      0.110
- A**
  - B** \*
  - C**
  - D**

7. What number goes in the blank if the numbers are ordered from *least* to *greatest*?

0.541 0.596 0.601 \_\_\_?\_\_\_ 0.615 0.650

- A** 0.600
- B** 0.610 \*
- C** 0.616
- D** 0.620

5. Which number is *greater* than 255.037?

- A** 254.051
- B** 255.008
- C** 254.099
- D** 255.043 \*

## ARMT GRADE 5 MATHEMATICS

8. The times shown below are practice speeds, in miles per hour, of cars at a racetrack. The speeds are ordered from *greatest* to *least*.

134.856      134.718      134.068            133.682      133.618

Which number belongs in the ?

134.091

**A**

134.102

**B**

133.793

**C \***

133.567

**D**

9. The results of a gymnastic event are shown in the chart below.

**Gymnastic Results**

Name	Score
Arin	28.3
Michael	27.245
Jarrell	27.25
Tomoki	27.9

Which gymnast had the *greatest* score?

- A** Arin \*  
**B** Michael  
**C** Jarrell  
**D** Tomoki

10. About 12,000 people attended a ball game during the weekend.

Which number is *closest* to 12,000?

- A** 12,050  
**B** 11,964 \*  
**C** 12,935  
**D** 11,500

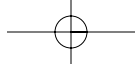

## ARMT GRADE 5 MATHEMATICS

### Answer Key

#### Content Standard 1

#### Sample Multiple-Choice

1. C
2. A
3. D
4. B
5. D
6. A
7. B
8. C
9. A
10. B

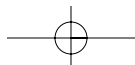
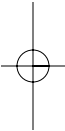
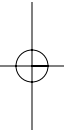

**ARMT GRADE 5 MATHEMATICS****NUMBER AND OPERATIONS****Content Standard 2**

**Solve problems involving basic operations on whole numbers, including addition and subtraction of seven-digit numbers, multiplication with two-digit multipliers, and division with two-digit divisors.**

**Item Type**

Multiple-choice  
Gridded  
Open-ended

**Additional Information**

Word problems/real-life situations may be used.

Bare computational problems may be used.

Tables and charts may be used only for graphic organization of information.

Fractions will not be used.

Multiple steps may be used.

Money values may be used.

One of the options may be NH, which means "Not Here."

**Sample Multiple-Choice Items**

1. 
$$\begin{array}{r} 49 \\ \times 23 \\ \hline \end{array}$$

- A** 245
- B** 792
- C** 1127 \*
- D** NH

2. In the magazine aisle at the grocery store there are 17 rows of magazines. In each row there are 13 magazines. How many magazines are in the aisle?

- A** 30
- B** 221 \*
- C** 421
- D** NH

**ARMT GRADE 5 MATHEMATICS****Sample Gridded Items**

1. Dana sold 29 purses for a total of \$928, including tax. Each purse was sold for an equal amount.

What was the cost of each purse?

Mark your answer in the answer grid.

4. The school auditorium has 48 rows. There are 25 seats in each row.

What is the total number of seats in the school auditorium?

Mark your answer in the answer grid.

2. A factory has 1440 items to put into boxes. Each box will hold 24 items.

What is the *least* number of boxes the factory will need?

Mark your answer in the answer grid.

5. Jackie bought a 192-ounce container full of water. She wants to use the water to fill bottles. Each bottle holds 12 ounces.

What is the *greatest* number of 12-ounce bottles Jackie could fill with the water from the 192-ounce container?

Mark your answer in the answer grid.

3. Eleven cattle ranchers sold a total of 7,832 cattle. Each cattle rancher sold an equal number of cattle.

What was the number of cattle sold by each cattle rancher?

Mark your answer in the answer grid.

**ARMT GRADE 5 MATHEMATICS****Sample Open-Ended Items**

This problem requires you to show your work and/or explain your reasoning. You may use drawings, words, and/or numbers. Your answer should be written so that another person could read and understand it. It is important that you show all your work.

1. The table below shows the capacities of 6 cargo ships.

**Ship Cargo Capacities**

<b>Ship Name</b>	<b>Capacity (in pounds)</b>
Anabel	1,097,912
Eglin	876,137
General	1,574,935
Mirasol	713,954
Phoenix	997,471
Westminster	869,553

- a. What is 1 *possible* list of 3 ships that have a combined capacity of *at least* 2,900,000 pounds? What is the total combined capacity of the 3 ships you listed?
- b. What is a *different* list of 3 ships that have a combined capacity of *at least* 2,900,000 pounds? What is the total combined capacity of the 3 ships you listed?

Show all your work and/or explain your reasoning *for each part* in the space provided in the answer document.

**ARMT GRADE 5 MATHEMATICS**

This problem requires you to show your work and/or explain your reasoning. You may use drawings, words, and/or numbers. Your answer should be written so that another person could read and understand it. It is important that you show all your work.

2. The table below shows the number of points John earned playing a computer game on different dates.

**Points Earned**

<b>Date</b>	<b>Number of Points</b>
July 1	453,921
July 6	576,818
July 10	789,326
July 12	1,205,783
July 15	1,000,326

- a. On which date did John *first* have a total of *at least* 1,500,000 points? When he finished playing the video game on the date you gave, what is the total number of points John had earned?
- b. John will play the same game for the last time this month on July 17. Explain a way he can score a total of *exactly* 5,000,000 points during July.

Show all your work and/or explain your reasoning *for each part* in the space provided in the answer document.

**ARMT GRADE 5 MATHEMATICS**

This problem requires you to show your work and/or explain your reasoning. You may use drawings, words, and/or numbers in your answer. Your answer should be written so that another person could read it and understand your reasoning. It is important that you show all your work.

3. The table below shows the populations of six U.S. cities in the year 2000.

**City Populations in 2000**

<b>City</b>	<b>Population</b>
Chicago, Illinois	2,896,016
Jacksonville, Florida	735,617
Memphis, Tennessee	650,100
Phoenix, Arizona	1,321,045
San Antonio, Texas	1,144,646
San Diego, California	1,223,400

- a. What is 1 *possible* list of 3 cities that have a combined total population of *at least* 4,600,000? What is the total population of the cities you listed?
- b. What is a *different* list of 3 cities that have a combined total population of *at least* 4,600,000? What is the total population of the cities you listed?

Show all your work and/or explain your reasoning *for each part* in the space provided in the answer document.

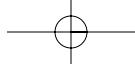

## ARMT GRADE 5 MATHEMATICS

### Answer Key

#### Content Standard 2

##### Sample Multiple-Choice

1. C
2. B

##### Sample Gridded

1. 32
2. 60
3. 712
4. 1200
5. 16

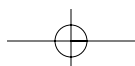
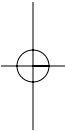
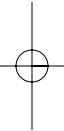

## ARMT GRADE 5 MATHEMATICS

### Sample Open-Ended

#### 1. Sample Response(s):

**a.**

Anabel	1,097,912
Eglin	876,137
General	<u>+ 1,574,935</u>
	3,548,984 is greater than 2,900,000 pounds

I picked these 3 cargo ships because they have a total of more than 2,900,000 pounds.

**b.**

General	1,574,935
Mirasol	713,954
Westminster	<u>+ 869,553</u>
	3,158,442

I picked these 3 cargo ships because it is a different list and still has a total of more than 2,900,000 pounds.

Score Point	Response Attributes
<b>3</b>	All is correct.
<b>2</b>	Both logics are correct. OR One logic and both answers are correct.
<b>1</b>	One or both answers are correct. OR One logic is correct.
<b>0</b>	None correct. (Also, blanks, rewrites problem, foreign language, illegible, refusals, off-task, etc., scored as invalid.)

## ARMT GRADE 5 MATHEMATICS

### 2. Sample Response(s):

- a. The date John first had a total of at least 1,500,00 points was on July 10. On July 10, John had a total of 1,820,065 points.

$$\begin{array}{r} 453,921 \\ 576,818 \\ + 789,326 \\ \hline 1,820,065 \end{array}$$

- b. On July 17, John will have to score 973,826 points to have a total of exactly 5,000,000 points. I found this by adding up all the numbers in the chart (4,026,174) and subtracting it from 5,000,000.  
(5,000,000 – 4,026,174 = 973,826)

Score Point	Response Attributes
<b>3</b>	All is correct.
<b>2</b>	Both logics are correct. OR One logic and both answers are correct.
<b>1</b>	One or both answers are correct. OR One logic is correct.
<b>0</b>	None correct. (Also, blanks, rewrites problem, foreign language, illegible, refusals, off-task, etc., scored as invalid.)



## ARMT GRADE 5 MATHEMATICS

## NUMBER AND OPERATIONS

**Content Standard 3**

Solve word problems that involve decimals, fractions, or money.

**Item Type**

Multiple-choice

Open-ended

**Additional Information**

Word problems/real-life situations may be used.

Tables and charts may be used only for graphic organization of information.

Multiple steps may be used.

Fractions may or may not need to be in their simplest form.

One of the options may be NH, which means "Not Here."

**Sample Multiple-Choice Items**

1. Ms. Buie took her son and daughter to buy school supplies. Her son's supplies cost \$23.94 and her daughter's supplies cost \$19.07.

If tax is included in the totals, how much did Ms. Buie spend on the school supplies?

- A** \$43.01 \*  
**B** \$42.10  
**C** \$33.11  
**D** \$32.91

2. Melinda has  $6\frac{3}{4}$  cups of sugar in her sugar canister. She used all but  $2\frac{1}{4}$  cups of sugar from the canister to make cookies.

How many cups of sugar did Melinda use to make the cookies?

- A** 9  
**B**  $8\frac{1}{2}$   
**C**  $4\frac{1}{2}$  \*  
**D**  $4\frac{1}{4}$

## ARMT GRADE 5 MATHEMATICS

3. On a fishing trip, Garrett caught two fish. The first fish weighed 6.6 pounds and the second fish weighed 3.9 pounds.

How many more pounds is the first fish than the second fish?

- A** 2.7 \*
- B** 3.5
- C** 3.7
- D** NH

4. After school on Wednesday, Roland finished  $\frac{1}{3}$  of a math project.

The next day, he finished another  $\frac{1}{3}$  of the project.

What fraction of the math project did Roland finish after these two days?

- A**  $\frac{1}{9}$
- B**  $\frac{2}{9}$
- C**  $\frac{2}{6}$
- D**  $\frac{2}{3}$  \*

5. Before lunch, there was  $\frac{7}{12}$  of a whole cake left in a pan. After lunch, there was  $\frac{5}{12}$  of the whole cake left.

What fractional part of this cake was eaten during lunch?

- A**  $\frac{12}{24}$
- B**  $\frac{2}{24}$
- C**  $\frac{12}{12}$
- D**  $\frac{2}{12}$  \*

6. Jay's total bill at the shoe store was \$46.19. He gave the clerk \$50.00.

How much change should Jay get back from the clerk?

- A** \$ 3.19
- B** \$ 3.81 \*
- C** \$ 6.11
- D** \$16.19

**ARMT GRADE 5 MATHEMATICS****Sample Open-Ended Items**

This problem requires you to show your work and/or explain your reasoning. You may use drawings, words, and/or numbers in your answer. Your answer should be written so that another person could read it and understand your reasoning. It is important that you show all your work.

1. Lucy has \$25.00 to spend for her birthday. The table below shows the items she would like to buy with her money. All prices include tax. Lucy wants to spend *at least* \$20.00 but not more than \$25.00.

**Items to Buy**

<b>Item</b>	<b>Price</b>
Books about computers	\$7.99
Hair ribbons	\$4.74
Purse	\$15.45
Stereo headphones	\$9.83

- a. What is 1 *possible* list of items Lucy could buy that costs *at least* \$20.00 but not more than \$25.00?
- b. What is a *different* list of items Lucy could buy that costs *at least* \$20.00 but not more than \$25.00?

Show all your work and/or explain your reasoning *for each part* in the space provided in the answer document.

## ARMT GRADE 5 MATHEMATICS

This problem requires you to show your work and/or explain your reasoning. You may use drawings, words, and/or numbers in your answer. Your answer should be written so that another person could read it and understand your reasoning. It is important that you show all your work.

2. Larry is making a snack mix. He wants to have *at least* 2.000 pounds of the mix. He will choose from the items in the table below.

**Weight of Items**

<b>Item</b>	<b>Weight (in pounds)</b>
Cashews	0.623
Dried fruit	0.892
Peanuts	0.726
Pretzels	0.409
Raisins	0.315
Walnuts	0.569

- a. What is 1 *possible* list of 3 items that have a combined total weight of *at least* 2.000 pounds? What is the combined total weight of the 3 items you listed?
- b. What is a *different* list of 3 items that have a combined total weight of *at least* 2.000 pounds? What is the combined total weight of the 3 items you listed?

Show all your work and/or explain your reasoning *for each part* in the space provided in the answer document.

**ARMT GRADE 5 MATHEMATICS**

This problem requires you to show your work and/or explain your reasoning. You may use drawings, words, and/or numbers in your answer. Your answer should be written so that another person could read it and understand your reasoning. It is important that you show all your work.

3. Mrs. Ferris has \$30.00 to spend at the grocery store. The table below shows the items she wants to buy. All prices include tax. Mrs. Ferris wants to spend *at least* \$25.00 but not more than \$30.00.

**Items to Buy**

<b>Item</b>	<b>Price</b>
Cheese	\$4.31
Hamburger buns	\$1.27
Hamburger meat	\$8.75
Ice cream	\$3.79
Laundry detergent	\$7.99
Orange juice	\$2.45
Turkey	\$12.90

- a. What is 1 *possible* list of items Mrs. Ferris could buy that costs *at least* \$25.00 but not more than \$30.00?
- b. What is 1 *different* list of items Mrs. Ferris could buy that costs *at least* \$25.00 but not more than \$30.00?

Show all your work and/or explain your reasoning *for each part* in the space provided in the answer document.

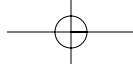

## ARMT GRADE 5 MATHEMATICS

### Answer Key

#### Content Standard 3

#### Sample Multiple-Choice

1. A
2. C
3. A
4. D
5. D
6. B

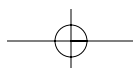
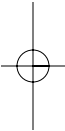
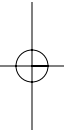

## ARMT GRADE 5 MATHEMATICS

### Sample Open-Ended

#### 1. Sample Response(s):

a. Book about computers	\$7.99
Hair ribbons	\$4.74
Stereo headphones	+ \$9.83
	\$22.56

I chose these 3 items because they total less than \$25.00 but more than \$20.00.

b. Purse	\$15.45
Book about computers	+ \$7.99
	\$23.44

I chose these 2 items because it is a different list, and they total less than \$25.00 but more than \$20.00.

Score Point	Response Attributes
<b>3</b>	All is correct.
<b>2</b>	Both logics are correct. OR One logic and both answers are correct.
<b>1</b>	One or both answers are correct. OR One logic is correct.
<b>0</b>	None correct. (Also, blanks, rewrites problem, foreign language, illegible, refusals, off-task, etc., scored as invalid.)

## ARMT GRADE 5 MATHEMATICS

### 2. Sample Response(s):

**a.**

Cashews	0.623
Dried Fruit	0.892
Peanuts	<u>+ 0.726</u>
	2.241

I chose these 3 items because they had a total weight of at least 2.000 pounds.

**b.**

Peanuts	0.726
Walnuts	0.569
Dried fruit	<u>+ 0.892</u>
	2.187

I chose these 3 items because it is a different list, and has a total weight of at least 2.000 pounds.

Score Point	Response Attributes
<b>3</b>	All is correct.
<b>2</b>	Both logics are correct. OR One logic and both answers are correct.
<b>1</b>	One or both answers are correct. OR One logic is correct.
<b>0</b>	None correct. (Also, blanks, rewrites problem, foreign language, illegible, refusals, off-task, etc., scored as invalid.)

## ARMT GRADE 5 MATHEMATICS

### 3. Sample Response(s):

a. Turkey	\$12.90
Laundry detergent	\$7.99
Cheese	<u>+ \$4.31</u>
	\$25.20

I chose these 3 items because they cost more than \$25.00 but less than \$30.00.

- b. Mrs. Ferris could buy 2 packages of Hamburger meat ( $\$8.75 \times 2 = \$17.50$ ), 2 packages of hamburger buns ( $\$1.27 \times 2 = \$2.54$ ), and 3 bottles of orange juice ( $\$2.45 \times 3 = \$7.35$ ) for a total price of \$27.39.

Score Point	Response Attributes
3	All is correct.
2	Both logics are correct. OR One logic and both answers are correct.
1	One or both answers are correct. OR One logic is correct.
0	None correct. (Also, blanks, rewrites problem, foreign language, illegible, refusals, off-task, etc., scored as invalid.)

## ARMT GRADE 5 MATHEMATICS

## NUMBER AND OPERATIONS

Content Standard 4

Determine the sum and difference of fractions with common and uncommon denominators.

Item Type

Multiple-choice

Gridded

Additional Information

No word problems/real-life situations will be used.

Bare computational problems will be used.

Mixed numbers may be used.

Reducing fractions may be required.

Sample Multiple-Choice Items

1.  $2\frac{1}{8} + 12\frac{7}{8} = \square$

- A** 14      **B**  $14\frac{8}{16}$       **C \*** 15      **D**  $15\frac{1}{8}$

2.  $\frac{13}{14} - \frac{9}{14} = \square$

- A**  $\frac{3}{14}$       **B \***  $\frac{4}{14}$       **C**  $\frac{4}{28}$       **D**  $\frac{22}{28}$

## ARMT GRADE 5 MATHEMATICS

3.  $16\frac{2}{7} - 7\frac{2}{7} = \square$

- 10       $9\frac{4}{7}$        $9\frac{2}{7}$       9  
**A**      **B**      **C**      **D\***

5.  $3\frac{5}{8} - 2\frac{1}{2} = \square$

- $1\frac{1}{8}$        $1\frac{4}{6}$        $1\frac{4}{8}$        $1\frac{1}{4}$   
**A\***      **B**      **C**      **D**

4.  $6\frac{2}{7} + 1\frac{3}{7} = \square$

- $7\frac{5}{7}$        $7\frac{6}{7}$        $7\frac{5}{14}$        $7\frac{6}{14}$   
**A\***      **B**      **C**      **D**

6.  $2\frac{2}{5} + 6\frac{3}{10} = \square$

- $8\frac{6}{50}$        $8\frac{7}{10}$        $8\frac{5}{10}$        $8\frac{5}{15}$   
**A**      **B\***      **C**      **D**

**ARMT GRADE 5 MATHEMATICS****Sample Gridded Items**

1.  $\frac{5}{6} - \frac{1}{3} = \square$

Mark your answer in the answer grid.

4.  $\frac{5}{8} - \frac{3}{10} = \square$

Mark your answer in the answer grid.

2.  $\frac{9}{10} + \frac{1}{4} = \square$

Mark your answer in the answer grid.

5.  $\frac{15}{16} - \frac{3}{4} = \square$

Mark your answer in the answer grid.

3.  $\frac{2}{9} + \frac{2}{6} = \square$

Mark your answer in the answer grid.

6.  $\frac{9}{10} - \frac{17}{20} = \square$

Mark your answer in the answer grid.

**ARMT GRADE 5 MATHEMATICS****Answer Key****Content Standard 4****Sample Multiple-Choice**

1. C
2. B
3. D
4. A
5. A
6. B

**Sample Gridded Items**

1.  $\frac{3}{6}$  or  $\frac{1}{2}$  or 0.5
2.  $\frac{23}{20}$  or  $1\frac{3}{20}$  or 1.15
3.  $\frac{30}{54}$  or  $\frac{15}{27}$  or  $\frac{10}{18}$  or  $\frac{5}{9}$  or 0.55 or 0.56
4.  $\frac{13}{40}$  or 0.325
5.  $\frac{3}{16}$  or 0.1875
6.  $\frac{1}{20}$  or 0.05

**ARMT GRADE 5 MATHEMATICS****NUMBER AND OPERATIONS****Content Standard 5**

Identify numbers less than zero by extending the number line.

**Item Type**

Multiple-choice

**Additional Information**

No word problems/real-life situations will be used.

A number line may be used.

A thermometer may be used.

**Sample Multiple-Choice Items**

1. What number is 15 spaces to the left of 7 on the number line below?

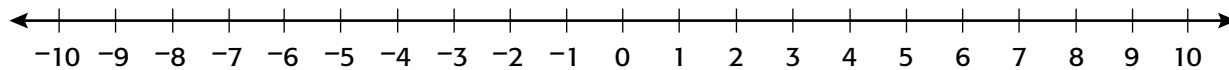

-10

**A**

-8

**B \***

2

**C**

7

**D**

## ARMT GRADE 5 MATHEMATICS

2. What number is 5 spaces to the left of 3 on the number line below?

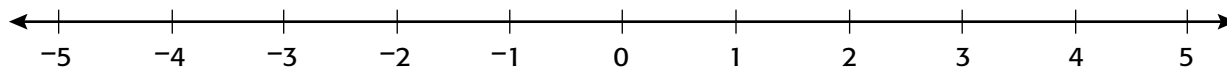

8

**A**

2

**B**

-2

**C \***

-7

**D**

3. What number is 9 spaces to the left of 0 on the number line below?

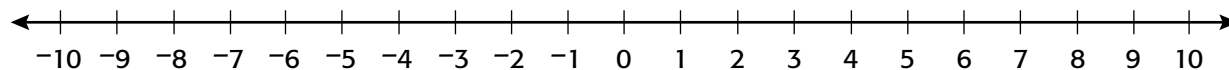

9

**A**

8

**B**

-8

**C**

-9

**D \***

4. What number is 5 spaces to the left of 1 on the number line below?

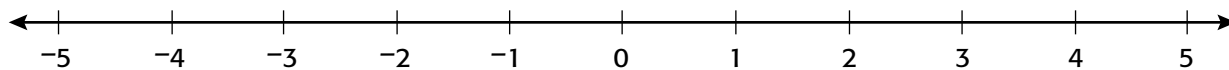

-6

**A**

-4

**B \***

4

**C**

6

**D**

## ARMT GRADE 5 MATHEMATICS

Look at the thermometer below.

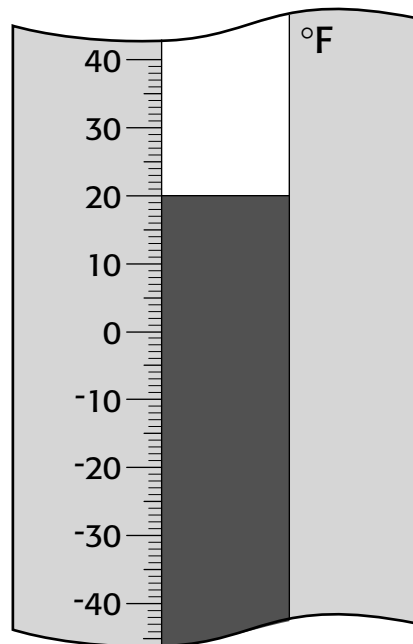

5. What will be the temperature, in degrees Fahrenheit, if it drops 30 degrees?

$-30^\circ$        $-10^\circ$        $30^\circ$        $50^\circ$   
**A**          **B \***          **C**          **D**

Look at the thermometer below.

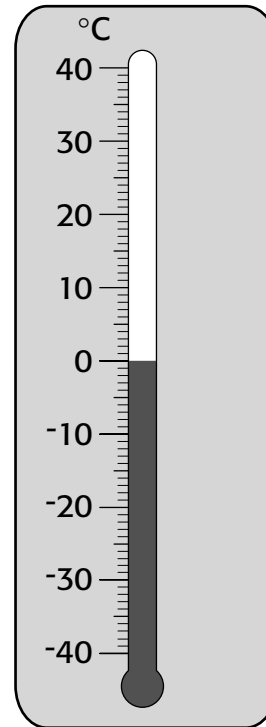

6. What will be the temperature, in degrees Celsius, if it drops 10 degrees?

$11^\circ$        $10^\circ$        $-9^\circ$        $-10^\circ$   
**A**          **B**          **C**          **D \***

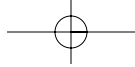

## ARMT GRADE 5 MATHEMATICS

### Answer Key

#### Content Standard 5

#### Sample Multiple-Choice

1. B
2. C
3. D
4. B
5. B
6. D

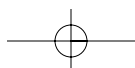
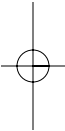
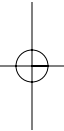

## ARMT GRADE 5 MATHEMATICS

## ALGEBRA

Content Standard 6

Demonstrate the commutative, associative, and identity properties of addition and multiplication of whole numbers.

Item Type

Multiple-choice

Additional Information

No word problems/real-life situations will be used.

Multiple steps may be required.

Parentheses may be used.

Sample Multiple-Choice Items

1. Which expression should go in the box to make the number sentence true?

$$9 \times 12 = \boxed{\phantom{000}}$$

- $12 \times 9$        $12 \div 9$        $12 - 9$        $12 + 9$   
**A** \*      **B**      **C**      **D**

2. Which number sentence below demonstrates the identity property of multiplication?

- A**  $6 \times (4 \times 3) = 6 \times 4$   
**B**  $3 \times (6 + 5) = (3 \times 6)(3 \times 5)$   
**C**  $(175 \times 25) \times 0 = 0$   
**D**  $(89 + 25) \times 1 = 89 + 25$  \*

## ARMT GRADE 5 MATHEMATICS

3. Which of the following expressions would go in the  $\square$  to demonstrate the associative property of addition?

$$(14 + 17) + 25 + 9 = \square$$

- A**  $25 + (14 + 17) + 9$   
**B**  $(17 + 4) + 25 + 9$   
**C**  $25 + 9 + (14 + 17)$   
**D**  $14 + 17 + (25 + 9) *$

## ARMT GRADE 5 MATHEMATICS

4. Which number sentence below demonstrates the associative property of multiplication?

- A**  $24 \times (16 \times 11) = (16 \times 11) \times 24$
- B**  $(15 \times 27) \times 19 = 15 \times (27 \times 19)$  \*
- C**  $(61 \times 30) \times 7 = (61 \times 30) \times 7$
- D**  $72 \times (5 \times 12) = 72 \times (12 \times 5)$

5. Which property of whole numbers is demonstrated by the number sentence below?

$$12 + 36 + 4 = (12 + 36 + 4) \times 1$$

- A** Identity property of addition
- B** Commutative property of addition
- C** Identity property of multiplication \*
- D** Commutative property of multiplication

6. Which number sentence below demonstrates the identity property of addition?

- A**  $(36 \times 4) + 19 = 19 + (36 \times 4)$
- B**  $0 + (410 \times 10) = 410 \times 10$  \*
- C**  $(53 + 62) + 113 = 53 + (62 + 113)$
- D**  $(104 + 5) \times 1 = 104 + 5$

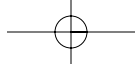

## ARMT GRADE 5 MATHEMATICS

### Answer Key

#### Content Standard 6

#### Sample Multiple-Choice

1. A
2. D
3. D
4. B
5. C
6. B

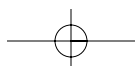
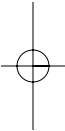
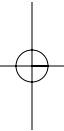

**ARMT GRADE 5 MATHEMATICS****ALGEBRA****Content Standard 7**

Write a number sentence for a problem expressed in words.

**Item Type**

Multiple-choice

**Additional Information**

Word problems/real-life situations will be used.

Up to seven-digit numbers may be used.

Money values may be used.

A box will be used.

**Sample Multiple-Choice Items**

1. The distance from Birmingham, Alabama, to Salt Lake City, Utah, is 1781 miles. This distance is 812 miles more than the distance from Birmingham, Alabama, to New York City.

Which number sentence below could be used to determine the distance, in miles, from Birmingham to New York City?

- A**  $\square + 1781 = 812$   
**B**  $1781 \times 812 = \square$   
**C**  $1781 = 812 \div \square$   
**D**  $\square = 1781 - 812 *$

## ARMT GRADE 5 MATHEMATICS

2. A local school district purchased computers and software for its schools. The total cost for the computers was \$1,431,505. The software costs \$68,495.

Which number sentence below could be used to determine the total cost of the computers and the software the school district bought?

- A**  $\$1,431,505 - \$68,495 = \square$   
**B**  $\$1,431,505 \div \$68,495 = \square$   
**C**  $\$1,431,505 + \$68,495 = \square$  \*  
**D**  $\$1,431,595 \times \$68,495 = \square$

4. Betty has 2,916 greeting cards to put into boxes. Each box will hold 18 cards.

Which number sentence below could be used to determine the number of boxes Betty will use for the greeting cards?

- A**  $2,916 \div 18 = \square$  \*  
**B**  $\square = 2,916 \times 18$   
**C**  $2,916 - \square = 18$   
**D**  $\square + 18 = 2,916$

3. The local amusement park had 1,306,250 people visit in 2003. In 2002, the amusement park had 78,500 fewer people visit.

Which number sentence below could be used to determine the number of people who visited the amusement park in 2002?

- A**  $1,306,250 \div \square = 78,500$   
**B**  $78,500 = 1,306,250 \times \square$   
**C**  $1,306,250 - 78,500 = \square$  \*  
**D**  $\square = 1,306,250 + 78,500$

## ARMT GRADE 5 MATHEMATICS

5. Georgia became a state in 1788.  
Alabama became a state 31 years later.
- Which number sentence below could be used to determine the year Alabama became a state?

- A**  $1788 - \square = 31$   
**B**  $\square + 1788 = 31$   
**C**  $31 + \square = 1788$   
**D**  $\square - 31 = 1788$  \*

7. There are 1432 students in Victoria Middle School. There are 145 fewer students at Miller Middle School.
- Which number sentence below could be used to determine the number of students in Miller Middle School?

- A**  $\square = 1432 - 145$  \*  
**B**  $\square = 1432 + 145$   
**C**  $\square = 1432 \times 145$   
**D**  $\square = 1432 \div 145$

6. The school district built a new school with 45 classrooms. Regulations required that no classroom could hold more than 35 students.
- Which number sentence below could be used to show the *greatest* number of students that could attend this new school?

- A**  $45 \div 35 = \square$   
**B**  $\square = 35 \times 45$  \*  
**C**  $45 - 35 = \square$   
**D**  $\square = 45 + 35$

8. There are 40 apartments in a building. Each apartment has the same amount of floor space. All together, there are 32,000 square feet of floor space in the building.
- Which number sentence below could be used to determine the amount of floor space, in square feet, in *each* of the 40 apartments?

- A**  $\square \div 32,000 = 40$   
**B**  $32,000 \div 40 = \square$  \*  
**C**  $32,000 - \square = 40$   
**D**  $32,000 \times 40 = \square$

## ARMT GRADE 5 MATHEMATICS

9. The population of Phoenix is 1,321,045, the population of San Antonio is 1,144,646, and the population of Huntsville is 158,216.

Which number sentence below could be used to determine the difference between the population of Phoenix and the combined populations of Huntsville and San Antonio?

- A**  $1,321,045 + (1,144,646 - 158,216) = \square$
- B**  $1,321,045 - (1,144,646 + 158,216) = \square *$
- C**  $1,321,045 + (1,144,646 + 158,216) = \square$
- D**  $1,321,045 - (1,144,646 - 158,216) = \square$

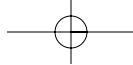

## ARMT GRADE 5 MATHEMATICS

### Answer Key

#### Content Standard 7

#### Sample Multiple-Choice

1. D
2. C
3. C
4. A
5. D
6. B
7. A
8. B
9. B

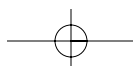
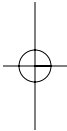
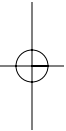

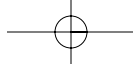

## ARMT GRADE 5 MATHEMATICS

### GEOMETRY

#### **Content Standard 8**

**Identify regular polygons and congruent polygons.**

#### **Item Type**

Multiple-choice

#### **Additional Information**

No word problems/real-life situations will be used.

Graphics will be used.

Length of sides and measures of angles will be given.

Right angles will be noted.

One of the two congruent polygons may be rotated.

#### **Sample Multiple-Choice Items**

(continued on next page)

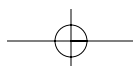
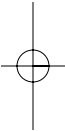
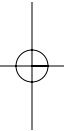

## ARMT GRADE 5 MATHEMATICS

1. Which of the following is a regular polygon?

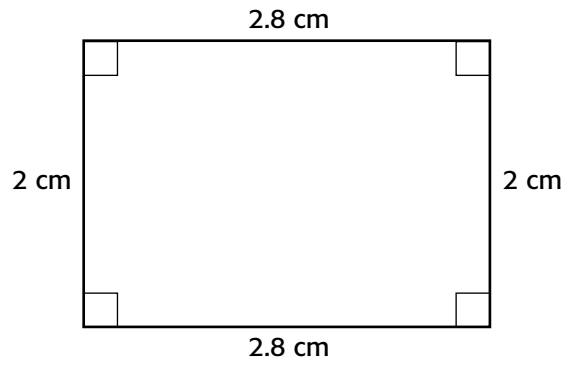
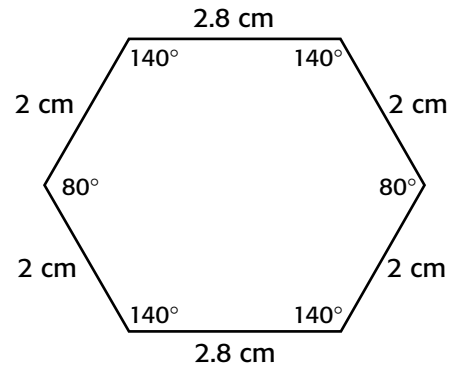
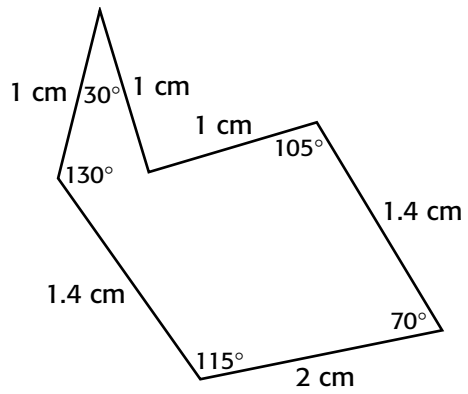
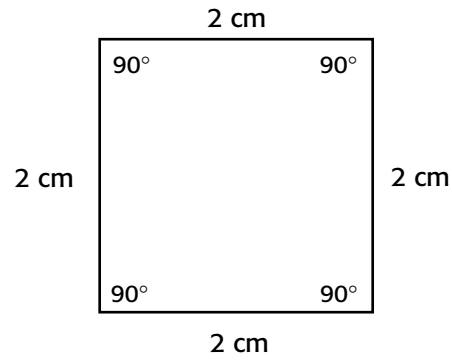
**A****C****B****D \***

## ARMT GRADE 5 MATHEMATICS

2. Which of the following is a regular polygon?

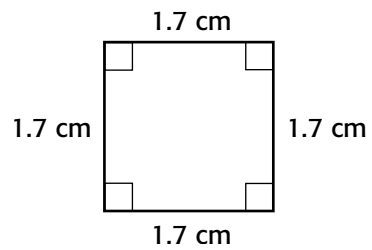

**A \***

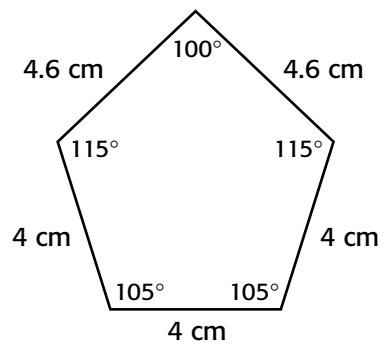

**C**

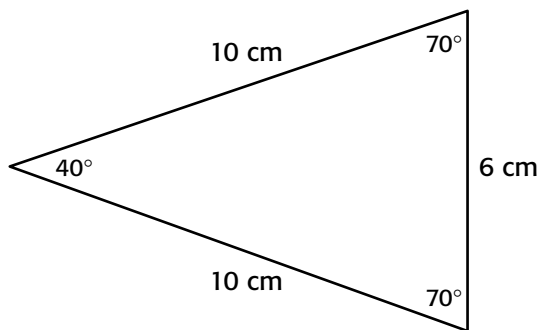

**B**

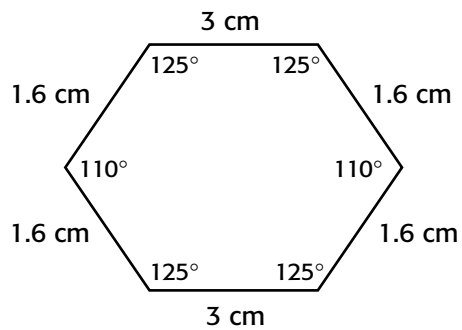

**D**

## ARMT GRADE 5 MATHEMATICS

3. Which of the following is congruent to the triangle below?

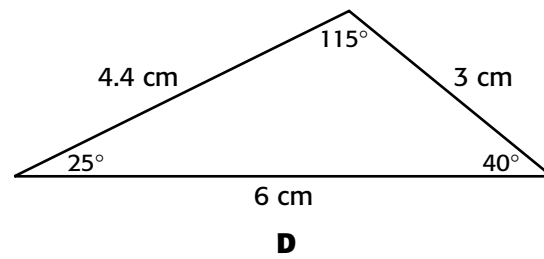
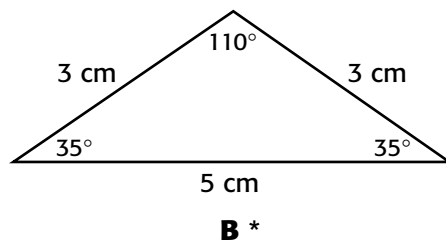
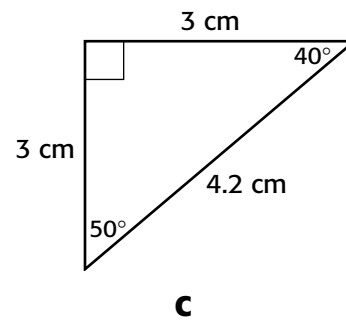
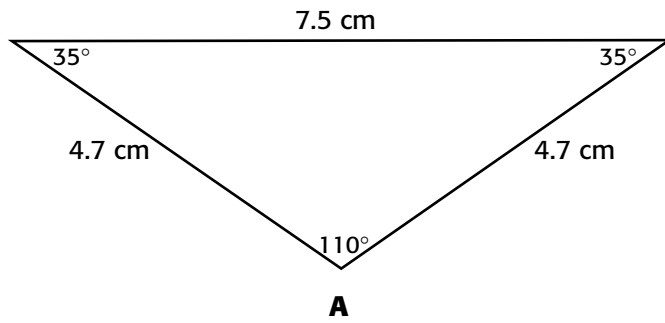
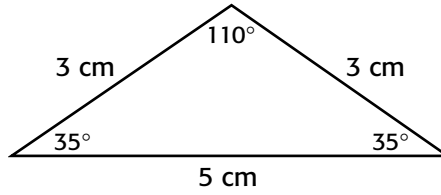

## ARMT GRADE 5 MATHEMATICS

4. Which of the following is congruent to the triangle below?

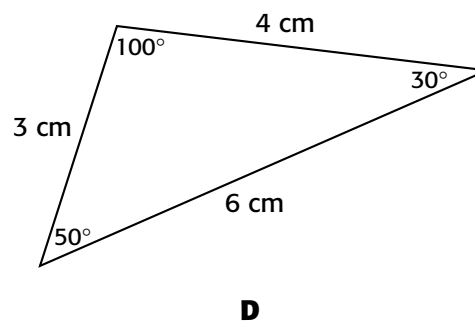
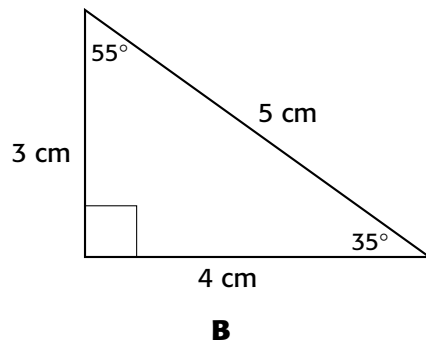
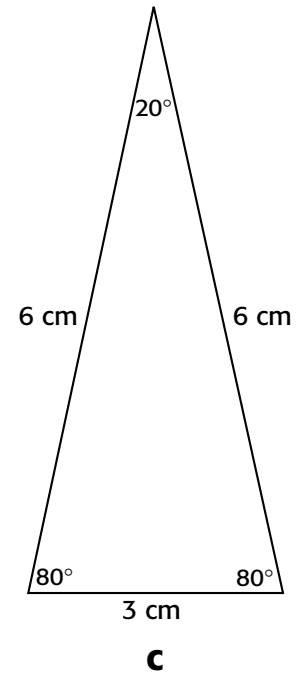
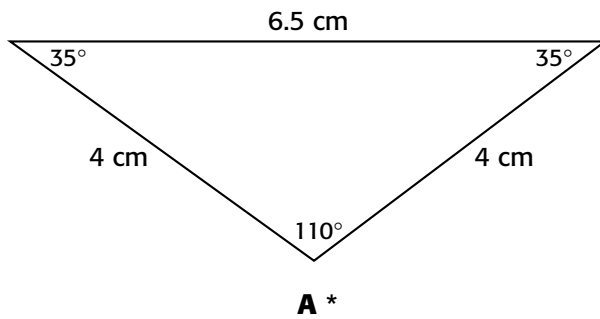
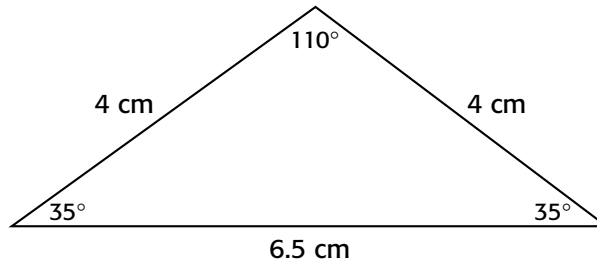

## ARMT GRADE 5 MATHEMATICS

5. Which of the following represents a pair of congruent polygons?

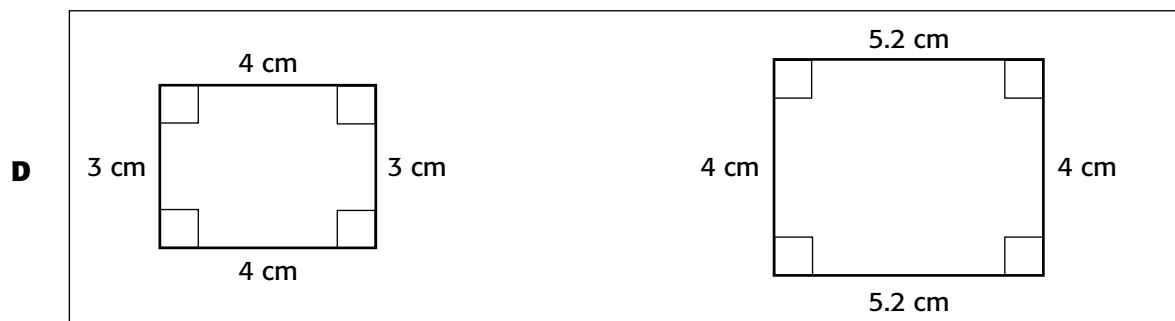
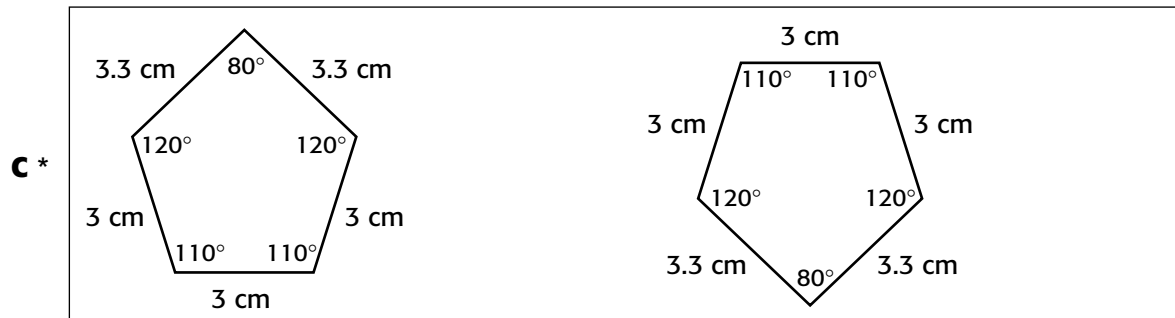
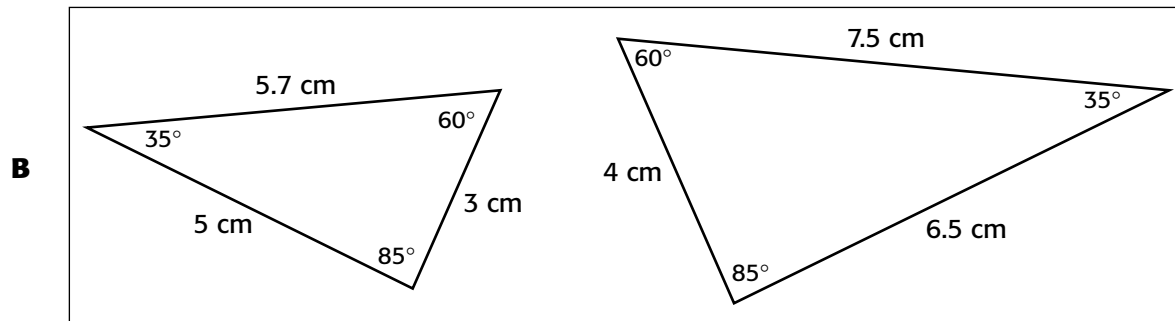
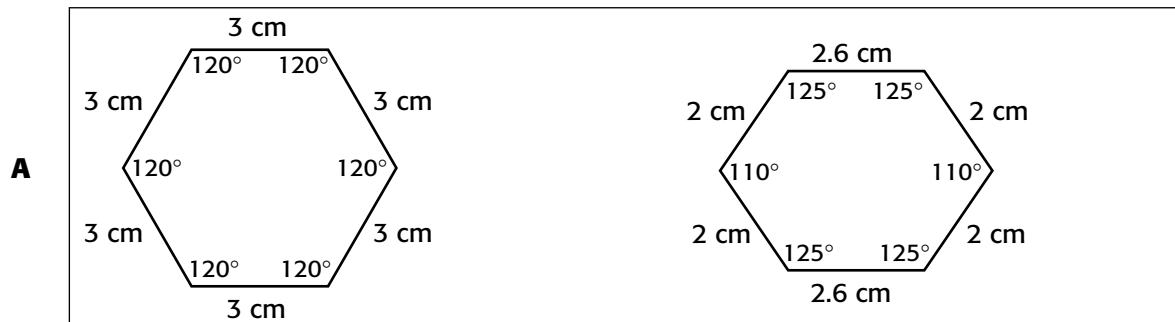

## ARMT GRADE 5 MATHEMATICS

6. Which of the following represents a pair of congruent polygons?

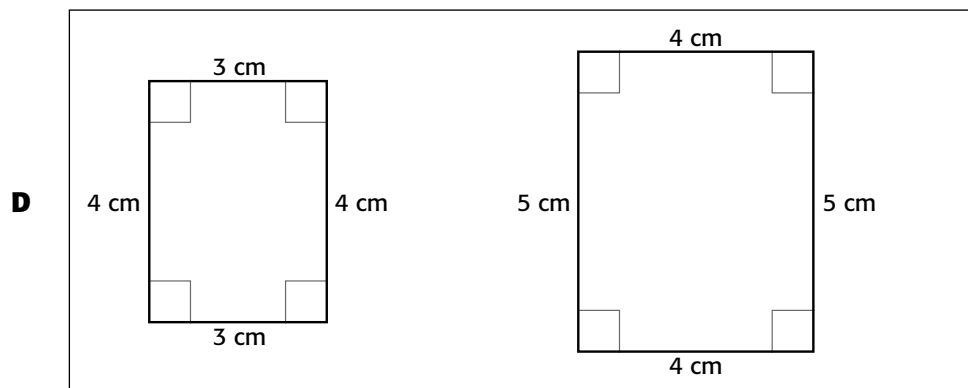
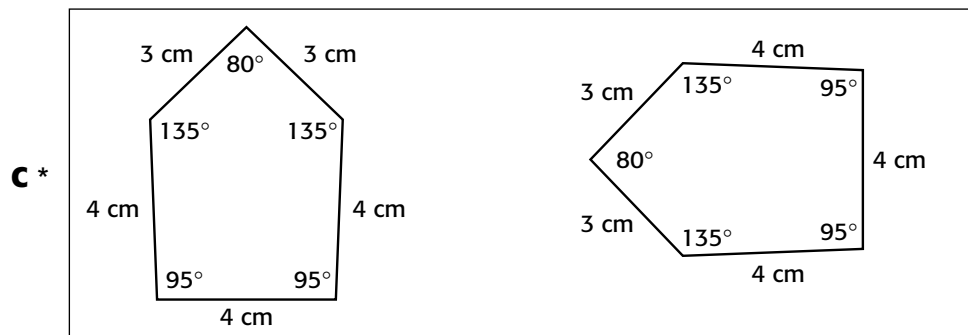
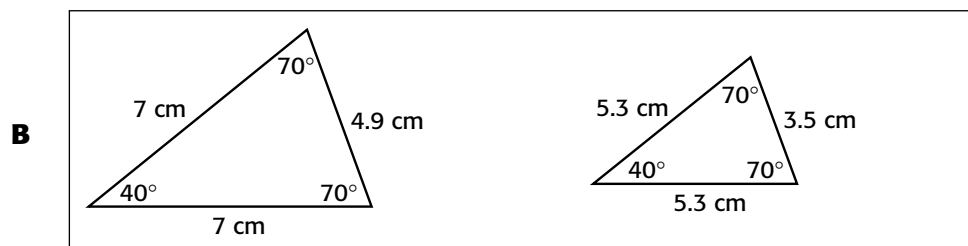
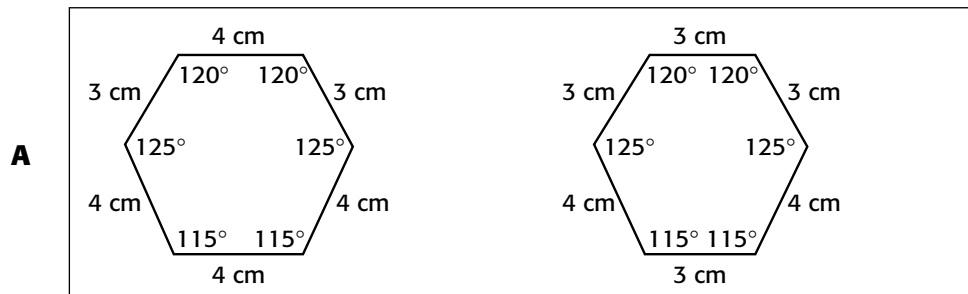

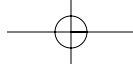

## ARMT GRADE 5 MATHEMATICS

### Answer Key

#### Content Standard 8

#### Sample Multiple-Choice

1. D
2. A
3. B
4. A
5. C
6. C

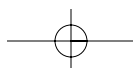
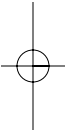
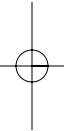

## ARMT GRADE 5 MATHEMATICS

## GEOMETRY

Content Standard 9

Identify components of the Cartesian plane, including the x-axis, y-axis, origin, and quadrants.

Item Type

Multiple-choice

Additional Information

No word problems/real-life situations will be used.  
Graphics may be used.

Sample Multiple-Choice Items

1. Which of the following points is located in Quadrant IV?

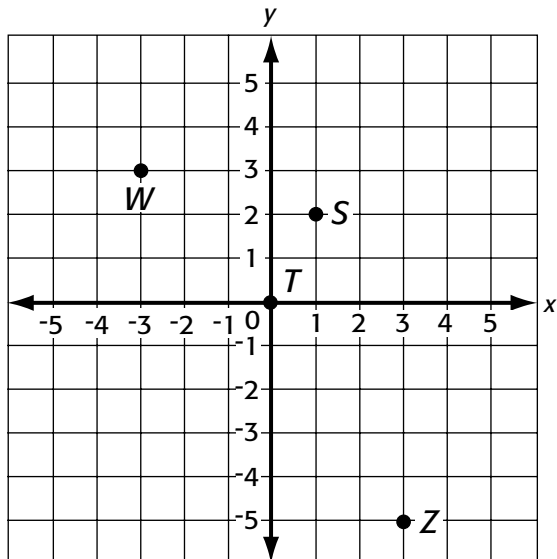

- W            S            T            Z  
**A**            **B**            **C**            **D**\*

2. Which of the following points appears to be located on the y-axis?

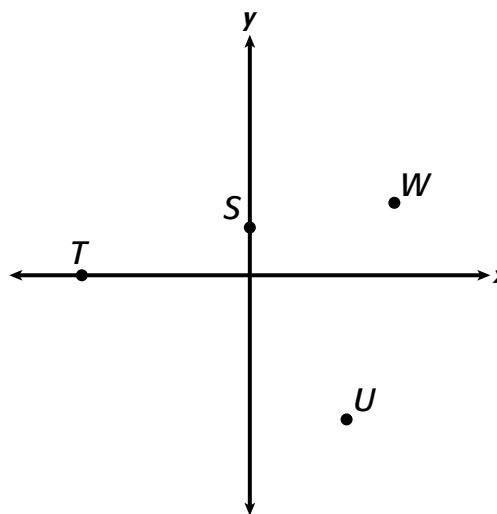

- S            T            U            W  
**A**\*            **B**            **C**            **D**

## ARMT GRADE 5 MATHEMATICS

3. Which of the following points is located in Quadrant III?

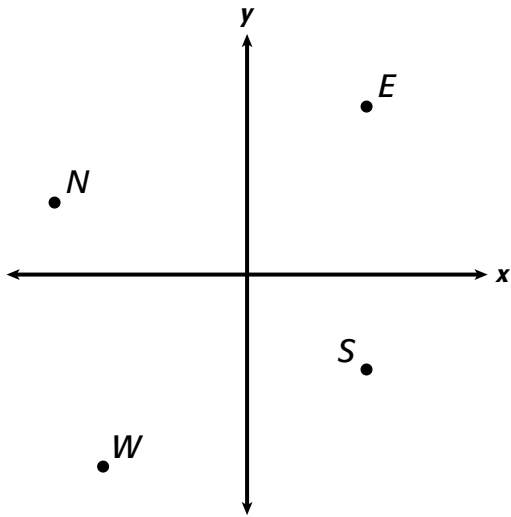

*E*      *N*      *S*      *W*  
**A**      **B**      **C**      **D**\*

4. In which quadrant is point *R* located?

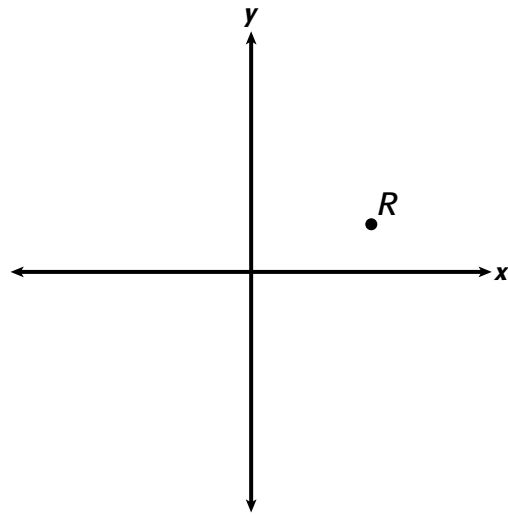

I      II      III      IV  
**A**\*      **B**      **C**      **D**

## ARMT GRADE 5 MATHEMATICS

5. Which of the following points appears to be located on the  $x$ -axis?

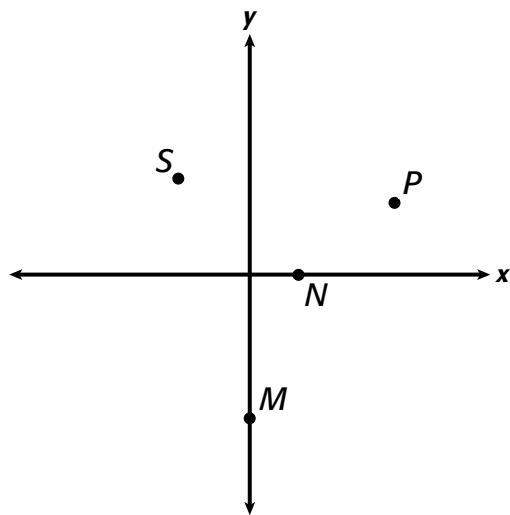

- $S$        $P$        $N$        $M$   
**A**      **B**      **C \***      **D**

6. Which of the following points is located in Quadrant II?

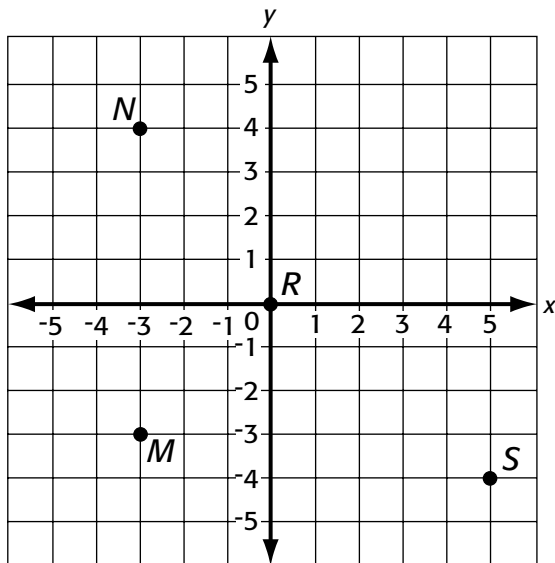

- $M$        $N$        $S$        $R$   
**A**      **B \***      **C**      **D**

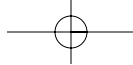

## ARMT GRADE 5 MATHEMATICS

### Answer Key

#### Content Standard 9

#### Sample Multiple-Choice

1. D
2. A
3. D
4. A
5. C
6. B

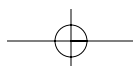
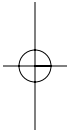
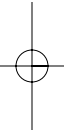

## ARMT GRADE 5 MATHEMATICS

## GEOMETRY

Content Standard 10

Identify the center, radius, and diameter of a circle.

Item Type

Multiple-choice

Additional Information

No word problems/real-life situations will be used.  
Graphics will be used.

Sample Multiple-Choice Items

Points  $E$ ,  $G$ , and  $H$  are on circle  $F$  below.

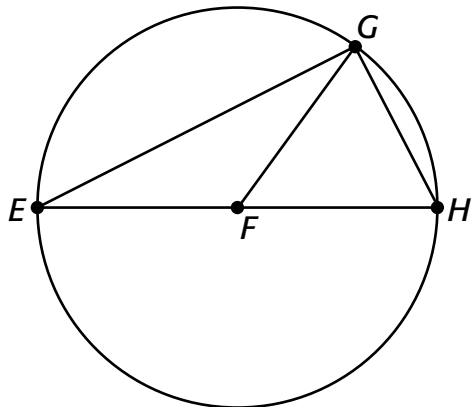

1. Which of the following segments *best* represents a diameter of circle  $F$ ?

$\overline{GH}$

**A**

$\overline{EH}$

**B \***

$\overline{GF}$

**C**

$\overline{EG}$

**D**

## ARMT GRADE 5 MATHEMATICS

Points  $L$ ,  $N$ ,  $K$ , and  $M$  are on circle  $J$  below.

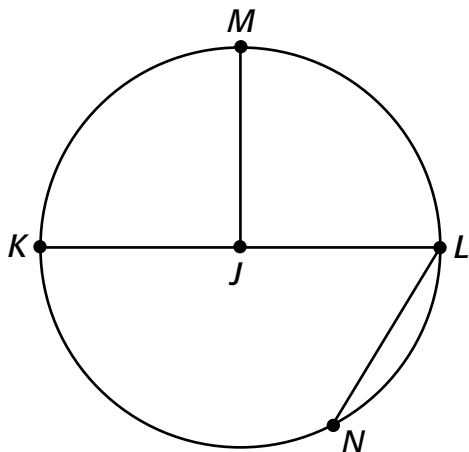

2. Which of the following segments *best* represents a diameter of circle  $J$ ?

- |                 |                 |                 |                 |
|-----------------|-----------------|-----------------|-----------------|
| $\overline{MJ}$ | $\overline{LK}$ | $\overline{NL}$ | $\overline{KJ}$ |
| <b>A</b>        | <b>B *</b>      | <b>C</b>        | <b>D</b>        |

Points  $P$ ,  $Q$ ,  $S$ , and  $M$  are on circle  $R$  below.

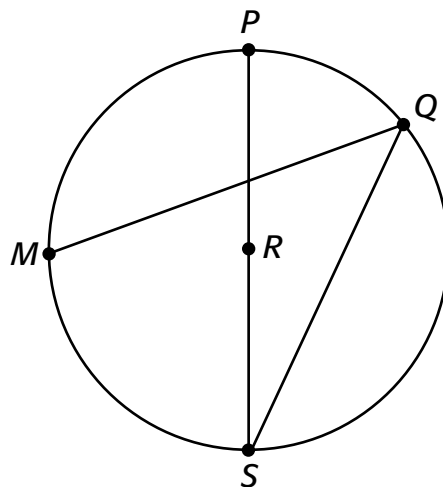

3. Which of the following segments is a radius of circle  $R$ ?

- |                 |                 |                 |                 |
|-----------------|-----------------|-----------------|-----------------|
| $\overline{PR}$ | $\overline{MQ}$ | $\overline{PS}$ | $\overline{QS}$ |
| <b>A *</b>      | <b>B</b>        | <b>C</b>        | <b>D</b>        |

ARMT GRADE 5 MATHEMATICS

Points  $T$ ,  $V$ ,  $U$ , and  $S$  are on circle  $O$  below.

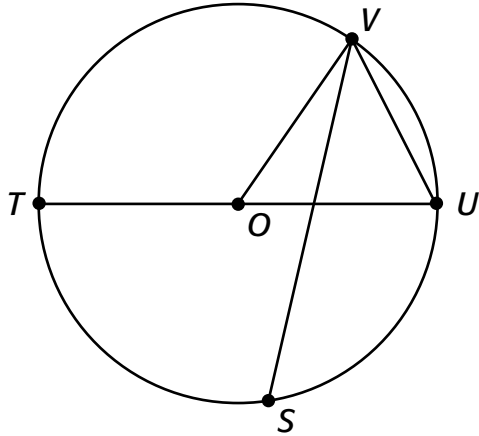

4. Which of the following segments is a radius of circle  $O$ ?

- $\overline{UV}$        $\overline{SV}$        $\overline{OT}$        $\overline{TU}$   
**A**          **B**          **C\***      **D**

5. Which of the following *best* represents the center of the circle below?

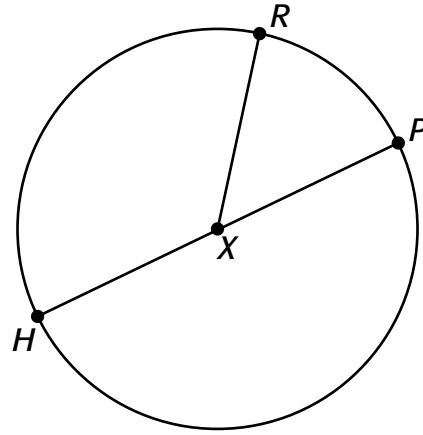

- $H$            $R$            $P$            $X$   
**A**          **B**          **C**          **D\***

6. Which letter *best* represents the center of the circle below?

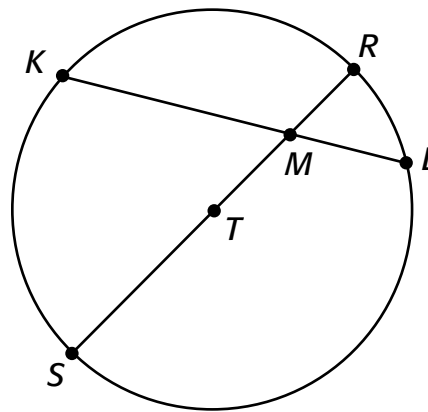

- $R$            $L$            $T$            $K$   
**A**          **B**          **C\***      **D**

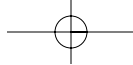

## ARMT GRADE 5 MATHEMATICS

### Answer Key

#### Content Standard 10

#### Sample Multiple-Choice

1. B
2. B
3. A
4. C
5. D
6. C

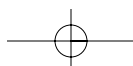
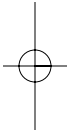
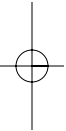

## ARMT GRADE 5 MATHEMATICS

## MEASUREMENT

Content Standard 11

Estimate perimeter and area of irregular shapes using unit squares and grid paper.

Item Type

Multiple-choice

Additional Information

No word problems/real-life situations will be used.

Graphics will be used.

Shapes will be shown using grid paper and unit squares.

In estimating perimeter and area, *closest* may be used.

Sample Multiple-Choice Items

1. Which is *closest* to the perimeter, in units, of the shaded figure below?

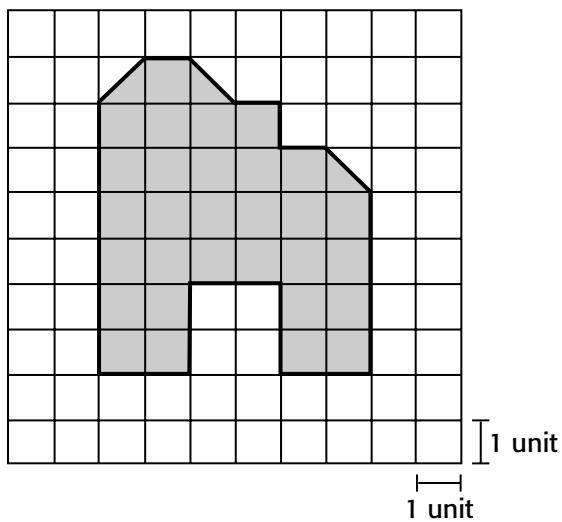

- 24      27      30      31  
**A**      **B \***      **C**      **D**

2. Which is *closest* to the perimeter, in units, of the shaded figure below?

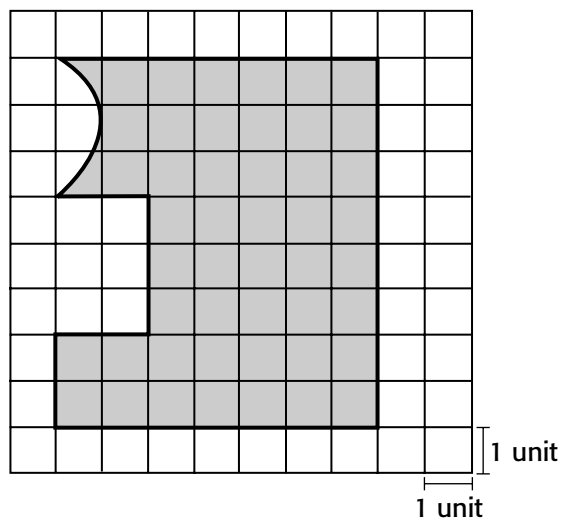

- 56      48      42      34  
**A**      **B**      **C**      **D \***

## ARMT GRADE 5 MATHEMATICS

3. Which is *closest* to the perimeter, in units, of the shaded figure below?

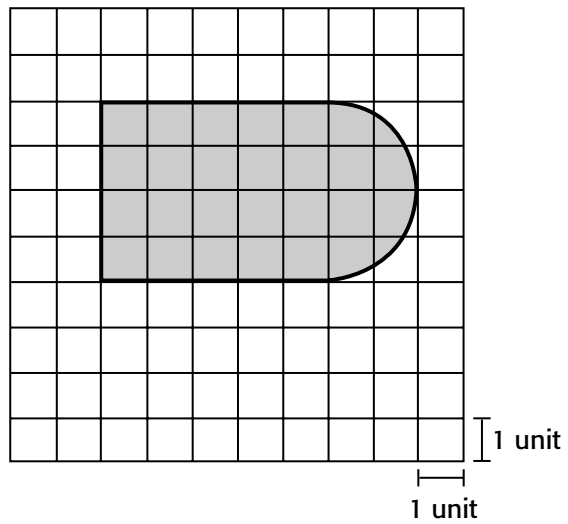

- 14      20      24      26  
**A**      **B \***      **C**      **D**

4. Which is *closest* to the area, in square units, of the shaded figure below?

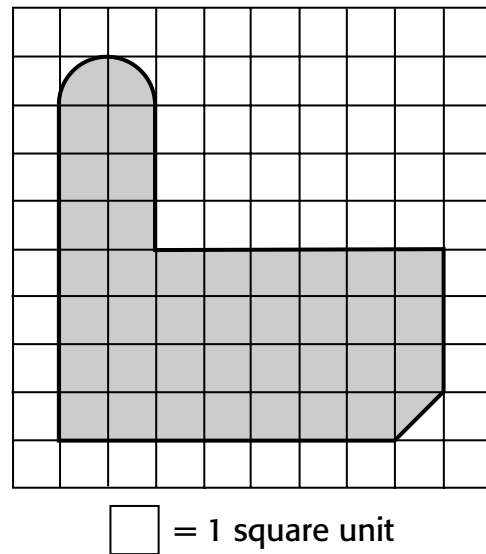

- 43      39      37      29  
**A**      **B \***      **C**      **D**

## ARMT GRADE 5 MATHEMATICS

5. Which is *closest* to the area, in square units, of the shaded figure below?

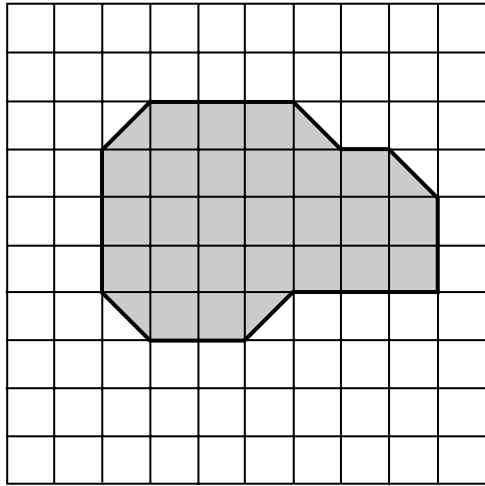

 = 1 square unit

- 19      25.5      27.5      35  
**A**      **B**      **C \***      **D**

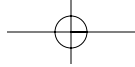

## ARMT GRADE 5 MATHEMATICS

### Answer Key

#### Content Standard 11

#### Sample Multiple-Choice

1. B
2. D
3. B
4. B
5. C

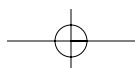
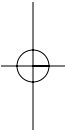
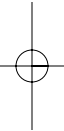

## ARMT GRADE 5 MATHEMATICS

## MEASUREMENT

Content Standard 12

Calculate the perimeter of rectangles from measured dimensions.

Item Type

Multiple-choice

Gridded

Additional Information

No word problems/real-life situations will be used.

Graphics may be used.

Measured dimensions will be given.

Metric or customary units will be used.

Sample Multiple-Choice Items

1. What is the perimeter, in meters, of a rectangle that is 13 meters long and 10 meters wide?

23      33      36      46  
**A**      **B**      **C**      **D \***

2. What is the perimeter, in meters, of the rectangle below?

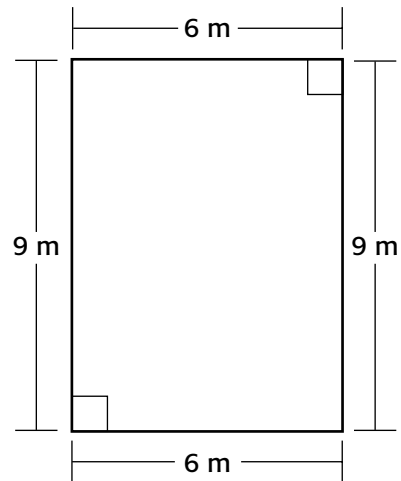

15      24      30      54  
**A**      **B**      **C \***      **D**

## ARMT GRADE 5 MATHEMATICS

3. What is the perimeter, in inches, of the rectangle shown below?

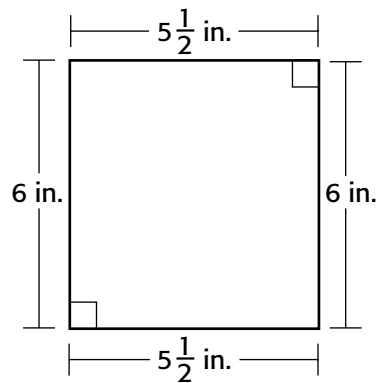

- $30\frac{1}{2}$       23      17       $11\frac{1}{2}$   
**A**      **B \***      **C**      **D**

4. What is the perimeter, in centimeters, of a rectangle that is 4 centimeters wide and 16 centimeters long?

- 20      36      40      64  
**A**      **B**      **C \***      **D**

**ARMT GRADE 5 MATHEMATICS****Sample Gridded Items**

1. What is the perimeter, in centimeters, of the rectangle shown below?

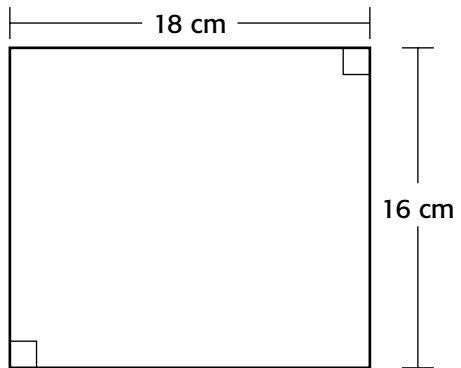

Mark your answer in the answer grid.

2. What is the perimeter, in inches, of the rectangle shown below?

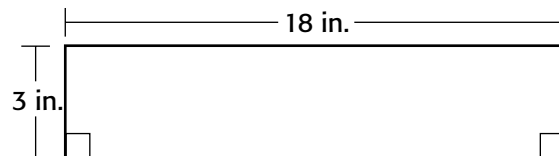

Mark your answer in the answer grid.

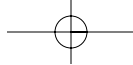

## ARMT GRADE 5 MATHEMATICS

### Answer Key

#### Content Standard 12

##### Sample Multiple-Choice

1. D
2. C
3. B
4. C

##### Sample Gridded

1. 68
2. 42

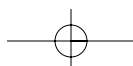
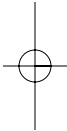
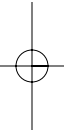

## ARMT GRADE 5 MATHEMATICS

## MEASUREMENT

**Content Standard 13**

Convert a larger unit of measurement to a smaller unit of measurement within the same system, customary or metric.

**Item Type**

Multiple-choice  
Gridded

**Additional Information**

Word problems/real-life situations may be used.  
Converting from a larger unit to a smaller unit will be required.  
Conversion units will not be provided.  
Each conversion will be within the same system.

**Sample Multiple-Choice Items**

1. On Tuesday, Takara drank 3 pints of bottled water.
- What is the total number of *ounces* in 3 pints?

64            48            24            6  
**A**            **B** \*            **C**            **D**

2. Dwayne needed 2 cups of milk to make biscuits.
- What is the total number of *ounces* in 2 cups?

16            12            8            4  
**A** \*            **B**            **C**            **D**

3. Amy's dog weighs 14 pounds.
- What is the dog's weight in *ounces*?

30            64            210            224  
**A**            **B**            **C**            **D** \*

## ARMT GRADE 5 MATHEMATICS

4. Max has 4 gallons of pickles.

What is the total number of *pints* of pickles Max has?

- 8            16            32            64  
**A**            **B**            **C \***            **D**

6. What number goes in the  to make the statement below true?

5 kilograms =  grams

- A** 50            **C** 5000 \*  
**B** 500            **D** 50,000

5. Jim has 16 gallons of orange juice.

What is the total number of *cups* of orange juice Jim has?

- 256            128            64            2  
**A \***            **B**            **C**            **D**

## ARMT GRADE 5 MATHEMATICS

7. What number goes in the  to make the statement below true?

250 meters =  centimeters

- A** 2500
- B** 25,000 \*
- C** 250,000
- D** 2,500,000

9. What number goes in the  to make the statement below true?

32 liters =  milliliters

- A** 320
- B** 3,200
- C** 32,000 \*
- D** 320,000

8. What number goes in the  to make the statement below true?

150 kilometers =  meters

- A** 15
- B** 1,500
- C** 15,000
- D** 150,000 \*

**ARMT GRADE 5 MATHEMATICS****Sample Gridded Items**

1. The distance from Jonna's house to her school is 147 yards.

What is the total number of *inches* in 147 yards?

Mark your answer in the answer grid.

3. Nancy is 5 feet tall.

What is the total number of *inches* in 5 feet?

Mark your answer in the answer grid.

2. Carolyn lives 3 miles from the post office.

What is the total number of *yards* in 3 miles?

Mark your answer in the answer grid.

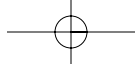

## ARMT GRADE 5 MATHEMATICS

### Answer Key

#### Content Standard 13

##### Sample Multiple-Choice

1. B
2. A
3. D
4. C
5. A
6. C
7. B
8. D
9. C

##### Sample Gridded

1. 5292
2. 5280
3. 60

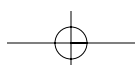
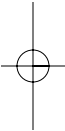
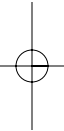

**ARMT GRADE 5 MATHEMATICS****DATA ANALYSIS AND PROBABILITY****Content Standard 14**

**Analyze data collected from a survey or experiment to distinguish between what the data show and what might account for the results.**

**Item Type**

Open-ended

**Additional Information**

Word problems/real-life situations will be used.

Tables and charts may be used only for graphic organization of information.

Time may be used.

**Sample Open-Ended Items**

(continued on next page)

**ARMT GRADE 5 MATHEMATICS**

This problem requires you to explain the results of a survey. Your answer should be written so that another person could read it and understand your reasoning.

1. Ricardo surveyed the students in his classes to determine their usual bedtime on school nights. The chart below shows his results.

**Students' Bedtime  
on School Nights**

<b>Bedtime</b>	<b>Number of Students</b>
Before 8:30 P.M.	5
8:30 P.M.	11
9:00 P.M.	21
9:30 P.M.	9
10:00 P.M.	3
After 10:00 P.M.	1

- a. What is the bedtime of the *greatest* number of students in Ricardo's survey?
- b. Give 2 *possible* reasons that could explain why students have different bedtimes.

Show all your work and/or explain your reasoning *for each part* in the space provided in the answer document.

**ARMT GRADE 5 MATHEMATICS**

This problem requires you to explain the results of a survey. Your answer should be written so that another person could read it and understand your reasoning.

2. The chart below shows the number of lawnmowers sold by a local store during selected months last year.

**Lawnmower Sales During  
Selected Months**

<b>Month</b>	<b>Number of Lawnmowers Sold</b>
March	17
May	42
July	23
September	12
December	5

- a. During which month was the *greatest* number of lawnmowers sold?
- b. Give 2 *possible* reasons that could explain why different numbers of lawnmowers were sold in different months.

Show all your work and/or explain your reasoning *for each part* in the space provided in the answer document.

## ARMT GRADE 5 MATHEMATICS

This problem requires you to explain the results of a survey. Your answer should be written so that another person could read it and understand your reasoning.

3. Merri surveyed several people to determine the months in which they go swimming. The chart below shows her results.

**Months to Swim**

<b>Month</b>	<b>Number of People</b>
March	21
July	30
September	23
October	10
December	2

- a. In which month did the *greatest* number of people go swimming?
- b. Give 2 *possible* reasons that could explain why the greatest numbers of people go swimming during the months you named in **part a**.

Show all your work and explain your reasoning *for each part* in the space provided in the answer document.

## ARMT GRADE 5 MATHEMATICS

This problem requires you to explain the results of a survey. Your answer should be written so that another person could read it and understand your reasoning.

4. The chart below shows the total number of kites sold at a local toy store during selected months last year.

**Kite Sales During  
Selected Months**

<b>Month</b>	<b>Number of Kites Sold</b>
March	75
June	52
September	12
December	5

- a. During which month was the *greatest* number of kites sold?
- b. Give 2 *possible* reasons that could explain why the *greatest* numbers of kites were sold in the month you named in **part a**.

Show all your work and/or explain your reasoning *for each part* in the space provided in the answer document.

## ARMT GRADE 5 MATHEMATICS

### Answer Key

#### Content Standard 14

#### Sample Open-Ended

<p><b>1. Sample Response(s):</b></p> <p><b>a.</b> 9:00 P.M. is the bedtime for the greatest number of students. I looked at the chart and the greatest number is 21.</p> <p><b>b.</b> One reason students might have different bedtimes is because of parents. Some parents make students go to bed earlier than other parents.</p> <p>Another reason students might have different bedtimes is because of sports. If students have to play a game during the week they might not get home until a later time.</p>	
Score Point	Response Attributes
<b>3</b>	All correct.
<b>2</b>	Both logics are correct, <div style="text-align: center;">OR</div> one logic is correct and the answer is correct.
<b>1</b>	One logic is correct, <div style="text-align: center;">OR</div> the answer is correct.
<b>0</b>	None correct. (Also, blanks, rewrites problem, foreign language, illegible, refusals, off-task, etc., scored as invalid.)

## ARMT GRADE 5 MATHEMATICS

### 2. Sample Response(s):

- a. The month of May had the greatest number of lawnmowers sold. I looked at the chart and the greatest number is 42.
- b. One reason there could have been a different number of lawnmowers sold is because in May the grass is starting to grow back and so more people have to cut their lawn. In December it is winter time and not many people are cutting their lawns.

Another reason there could have been a different number of lawnmowers sold is because spring is a time for planting grass and winter is not a good time to plant grass.

Score Point	Response Attributes
<b>3</b>	All correct.
<b>2</b>	Both logics are correct, OR one logic is correct and the answer is correct.
<b>1</b>	One logic is correct, OR the answer is correct.
<b>0</b>	None correct. (Also, blanks, rewrites problem, foreign language, illegible, refusals, off-task, etc., scored as invalid.)

## ARMT GRADE 5 MATHEMATICS

### 3. Sample Response(s):

- a. July is the month the greatest number of people went swimming. I looked at the chart and the greatest number is 30.
- b. One reason more people might go swimming in July is because that is the hottest time of the year for some areas.

Another reason more people might go swimming in July is because that is when it is summer for students.

Score Point	Response Attributes
<b>3</b>	All correct.
<b>2</b>	Both logics are correct, OR one logic is correct and the answer is correct.
<b>1</b>	One logic is correct, OR the answer is correct.
<b>0</b>	None correct. (Also, blanks, rewrites problem, foreign language, illegible, refusals, off-task, etc., scored as invalid.)

## ARMT GRADE 5 MATHEMATICS

### 4. Sample Response(s):

- a. March is the month that the greatest number of kites were sold from the local toy store. I looked at the chart and the greatest number is 75.
- b. One reason March could be the time when the greatest number of kites are sold is because that is when people like to go the coast and fly kites.

Another reason is because March is a windy month.

Score Point	Response Attributes
<b>3</b>	All correct.
<b>2</b>	Both logics are correct, OR one logic is correct and the answer is correct.
<b>1</b>	One logic is correct, OR the answer is correct.
<b>0</b>	None correct. (Also, blanks, rewrites problem, foreign language, illegible, refusals, off-task, etc., scored as invalid.)

## ARMT GRADE 5 MATHEMATICS

## DATA ANALYSIS AND PROBABILITY

**Content Standard 15**

Use common fractions to represent the probability of events that are neither certain nor impossible.

**Item Type**

Multiple-choice  
Gridded

**Additional Information**

Word problems/real-life situations will be used.

Tables and charts may be used only for graphic organization of information.

Graphics may be used.

Answers will never be certain (100%) or impossible (0%).

Answers for gridded items will be expressed in fractions.

Answers and distractors for multiple-choice items will be fractions.

**Sample Multiple-Choice Items**

1. Each letter in the word WASHINGTON is written on a separate piece of paper. Each piece of paper is the same size. The pieces of paper are put into a bag. One of the pieces of paper is selected from the bag at random.

What is the probability the letter on the first piece of paper selected will be an A, an I, or an O?

- |                |                |                |                |
|----------------|----------------|----------------|----------------|
| $\frac{3}{10}$ | $\frac{4}{10}$ | $\frac{6}{10}$ | $\frac{7}{10}$ |
| <b>A *</b>     | <b>B</b>       | <b>C</b>       | <b>D</b>       |

2. Elizabeth had 3 orange marbles, 2 green marbles, and 3 yellow marbles in a bag. There were no other marbles in the bag. Without looking, Elizabeth selected a marble from the bag.

What is the probability Elizabeth selected an orange marble from the bag?

- |               |               |               |               |
|---------------|---------------|---------------|---------------|
| $\frac{2}{8}$ | $\frac{3}{8}$ | $\frac{5}{8}$ | $\frac{6}{8}$ |
| <b>A</b>      | <b>B *</b>    | <b>C</b>      | <b>D</b>      |

## ARMT GRADE 5 MATHEMATICS

3. Each letter in the word CHATTAHOOCHEE is written on a separate piece of paper. Each piece of paper is the same size. The pieces of paper are put into a bag. One of the pieces of paper is selected from the bag at random.

What is the probability the letter on the first piece of paper selected will be an H?

- $\frac{2}{13}$        $\frac{3}{13}$        $\frac{6}{13}$        $\frac{10}{13}$   
**A**      **B \***      **C**      **D**

4. Jamal had a bag that had 4 orange marbles, 5 green marbles, and 6 white marbles. There were no other marbles in the bag. Jamal selected a marble from the bag without looking.

What is the probability Jamal selected a white marble?

- $\frac{4}{15}$        $\frac{5}{15}$        $\frac{6}{15}$        $\frac{9}{15}$   
**A**      **B**      **C \***      **D**

- The spinner shown below is divided into 6 equal sections. Each of the letters in the word CHEAHA is put on the spinner as shown.

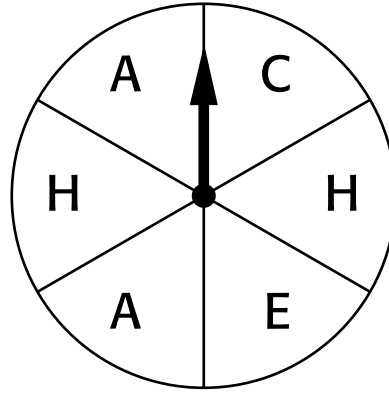

5. What is the probability on the first spin the arrow will land on a space with the letter A?

- $\frac{5}{6}$        $\frac{4}{6}$        $\frac{3}{6}$        $\frac{2}{6}$   
**A**      **B**      **C**      **D \***

## ARMT GRADE 5 MATHEMATICS

Sample Gridded Items

1. Jerry, Sandra, Peggy, Albert, and Sharon are on a basketball team. For the game on Tuesday, one of these players will be selected at random to be captain.

What is the probability either *Jerry* or *Albert* will be selected to be captain of the game on Tuesday?

Express your answer as a fraction.

Mark your answer in the answer grid.

The table below shows the hair color of all students in Gerry's class.

**Hair Color of Students**

<b>Hair Color</b>	<b>Number of Students</b>
Red	2
Brown	13
Black	4
Blond	6

2. What is the probability a student selected at random from Gerry's class will have blond hair?

Express your answer as a fraction.

Mark your answer in the answer grid.

**ARMT GRADE 5 MATHEMATICS**

3. On Monday, Travis, Maggie, Ellie, and Earl rode to school with Ellie's mother. Ellie's mother selected a child at random to sit in the front seat.

What is the probability that on Monday Ellie's mom selected Travis to sit in the front seat?

Express your answer as a fraction.

Mark your answer in the answer grid.

4. There were 25 students who attended a club meeting. From those in attendance, a student was selected at random to win a prize. Carrie attended the meeting.

What is the probability Carrie was selected to win the prize?

Express your answer as a fraction.

Mark your answer in the answer grid.

**ARMT GRADE 5 MATHEMATICS****Answer Key****Content Standard 11****Sample Multiple-Choice**

1. A
2. B
3. B
4. C
5. D

**Sample Gridded**

1.  $\frac{2}{5}$
2.  $\frac{6}{25}$
3.  $\frac{1}{4}$
4.  $\frac{1}{25}$

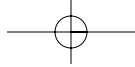

**ARMT GRADE 5 MATHEMATICS**

**SAMPLE RESPONSE  
FORMAT**

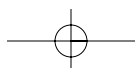
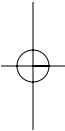
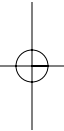

## ARMT GRADE 5 MATHEMATICS

## SAMPLE RESPONSE: MULTIPLE-CHOICE

1	A	B	C	D
2	A	B	C	D
3	A	B	C	D
4	A	B	C	D
5	A	B	C	D

6	A	B	C	D
7	A	B	C	D
8	A	B	C	D

9	A	B	C	D
10	A	B	C	D

SAMPLE

### ARMT GRADE 5 MATHEMATICS

## SAMPLE RESPONSE: GRIDDED

1

\$	.	.	.	.	.	.	.	.	.	.
	/	/	/	/	/	/	/	/	/	/
0	0	0	0	0	0	0	0	0	0	0
1	1	1	1	1	1	1	1	1	1	1
2	2	2	2	2	2	2	2	2	2	2
3	3	3	3	3	3	3	3	3	3	3
4	4	4	4	4	4	4	4	4	4	4
5	5	5	5	5	5	5	5	5	5	5
6	6	6	6	6	6	6	6	6	6	6
7	7	7	7	7	7	7	7	7	7	7
8	8	8	8	8	8	8	8	8	8	8
9	9	9	9	9	9	9	9	9	9	9

2

\$	.	.	.	.	.	.	.	.	.	.
	/	/	/	/	/	/	/	/	/	/
0	0	0	0	0	0	0	0	0	0	0
1	1	1	1	1	1	1	1	1	1	1
2	2	2	2	2	2	2	2	2	2	2
3	3	3	3	3	3	3	3	3	3	3
4	4	4	4	4	4	4	4	4	4	4
5	5	5	5	5	5	5	5	5	5	5
6	6	6	6	6	6	6	6	6	6	6
7	7	7	7	7	7	7	7	7	7	7
8	8	8	8	8	8	8	8	8	8	8
9	9	9	9	9	9	9	9	9	9	9

3

\$	.	.	.	.	.	.	.	.	.	.
	/	/	/	/	/	/	/	/	/	/
0	0	0	0	0	0	0	0	0	0	0
1	1	1	1	1	1	1	1	1	1	1
2	2	2	2	2	2	2	2	2	2	2
3	3	3	3	3	3	3	3	3	3	3
4	4	4	4	4	4	4	4	4	4	4
5	5	5	5	5	5	5	5	5	5	5
6	6	6	6	6	6	6	6	6	6	6
7	7	7	7	7	7	7	7	7	7	7
8	8	8	8	8	8	8	8	8	8	8
9	9	9	9	9	9	9	9	9	9	9

4

\$	.	.	.	.	.	.	.	.	.	.
	/	/	/	/	/	/	/	/	/	/
0	0	0	0	0	0	0	0	0	0	0
1	1	1	1	1	1	1	1	1	1	1
2	2	2	2	2	2	2	2	2	2	2
3	3	3	3	3	3	3	3	3	3	3
4	4	4	4	4	4	4	4	4	4	4
5	5	5	5	5	5	5	5	5	5	5
6	6	6	6	6	6	6	6	6	6	6
7	7	7	7	7	7	7	7	7	7	7
8	8	8	8	8	8	8	8	8	8	8
9	9	9	9	9	9	9	9	9	9	9

5

\$	.	.	.	.	.	.	.	.	.	.
	/	/	/	/	/	/	/	/	/	/
0	0	0	0	0	0	0	0	0	0	0
1	1	1	1	1	1	1	1	1	1	1
2	2	2	2	2	2	2	2	2	2	2
3	3	3	3	3	3	3	3	3	3	3
4	4	4	4	4	4	4	4	4	4	4
5	5	5	5	5	5	5	5	5	5	5
6	6	6	6	6	6	6	6	6	6	6
7	7	7	7	7	7	7	7	7	7	7
8	8	8	8	8	8	8	8	8	8	8
9	9	9	9	9	9	9	9	9	9	9

ARMT GRADE 5 MATHEMATICS

SAMPLE RESPONSE: OPEN-ENDED

Be sure to leave room in your answer space for all parts of this test question.

Answer question \_\_\_ in this box.

DO NOT WRITE OUTSIDE THE BOX.

DO NOT WRITE OUTSIDE THE BOX.

A large rectangular area filled with a grid of small squares, intended for writing an answer. A large, light gray watermark with the word "SAMPLE" is oriented diagonally across the grid from the bottom-left to the top-right.

DO NOT WRITE OUTSIDE THE BOX.